



TRANSCCELL TECHNOLOGY, INC.



MODEL **TI-500 RF Series**

**Digital Weight Indicator
(with wireless weighing capability)**

**Installer's
Manual**

Revision 1.6 April 16, 2018

©Transcell Technology, Inc. 2010-2018. All rights reserved.

The information contained herein is the property of Transcell Technology and is supplied without liability for errors or omissions. No part may be reproduced or used except as authorized by contract or other written permission. The copyright and the foregoing restriction on reproduction and use extend to all media in which the information may be embodied.

Contents subject to change without notice.

Contents

INSTALLATION & OVERVIEW	2
SCOPE OF TI-500 RF SERIES	2
INSTALLATION OF TI-500 RF DIGITAL INDICATOR.....	3
INSTALLATION OF TI-500 RF SS DIGITAL INDICATOR	5
INSTALLATION OF TI-500 RFTM REMOTE WIRELESS A/D MODULE.....	6
INSTALLATION OF LCT-1 REMOTE WIRELESS DIGITAL JUNCTION BOX.....	7
GETTING STARTED – CABLED SYSTEMS	9
GETTING STARTED – WIRELESS SYSTEMS	9
SYSTEM CONFIGURATION.....	10
CONFIGURATION MENUS.....	10
ENTERING THE SETUP (“F”) CONFIGURATION MENU.....	11
SETUP (“F”) MENU DESCRIPTIONS	11
ENTERING THE USER (“A”) OR COM (“C”) MENU.....	14
USER (“A”) AND COM (“C”) MENU DESCRIPTIONS	15
SETTING SYSTEM TIME AND DATE (A20).....	18
DIAGNOSTICS (A24).....	19
ENTERING THE BLUETOOTH (“B”) MENU	20
BLUETOOTH (“B”) MENU DESCRIPTIONS.....	20
BLUETOOTH PAIR PROCEDURE (B11).....	21
SYSTEM CALIBRATION	23
CALIBRATION OVERVIEW.....	23
DIGITAL CORNER CALIBRATION (DUAL WIRELESS UNITS ONLY)	23
DIGITAL ZERO/SPAN CALIBRATION (F16 AND F17)	24
KEY-IN ZERO CALIBRATION VALUE (F19)	25
KEY-IN SPAN CALIBRATION VALUE (F20)	25
RESTORE FACTORY CALIBRATION (B6) – WIRELESS SYSTEMS ONLY	26
SERIAL PORT INFO	27
SERIAL PORT MODES	27
OUTPUT STRINGS	28

INSTALLATION & OVERVIEW

Remember that the installer is ultimately responsible to assure that an installation will be and remain safe and operable under the specific conditions encountered.

This manual covers the following products:

<i>Model</i>	<i>Display</i>	<i>Antenna</i>	<i>Enclosure Type</i>
TI-500 RF	LCD	Internal	Aluminum/ABS
TI-500 RF SS	LCD	External	Stainless Steel
TI-500 RFTM-B1	N/a	Internal	ABS
TI-500 RFTM-B1E	N/a	External	ABS
LCT-1	N/a	Internal	ABS

Scope of TI-500 RF Series

Out of the box, the TI-500 RF series indicator operates as a basic, cabled digital weight indicator. The load cell(s) and/or j-box is connected to the indicator's internal A/D convertor. This configuration is depicted in the following diagram:

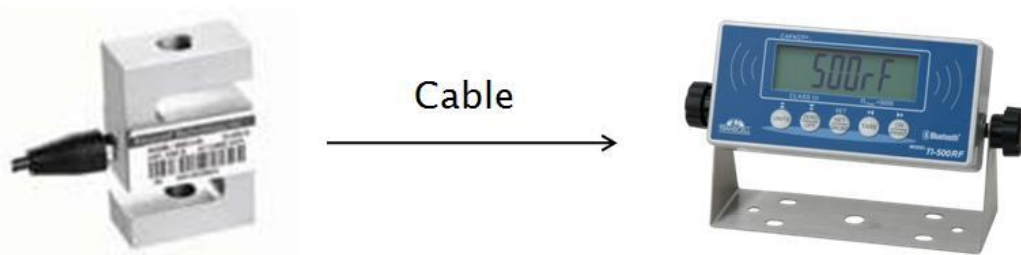

Conventional Load Cell
(with or without j-box)

TI-500 RF shown

When sold as part of a Smarter Weigh™ RF Kit, your TI-500 RF series indicator is transformed from "wired" to cable-free. This configuration is depicted in the following diagram:



Conventional Load Cell
(with or without j-box)

TI-500 RFTM-B1E

TI-500 RF

NOTE: A wireless LCT-1 junction box can be substituted for the TI-500 RFTM-B1E in the previous diagram.

Our products currently use reliable and popular Bluetooth® wireless technology.

This manual covers installation, configuration and calibration of the RF scale system. For operation and troubleshooting, please refer to the separate user's guide.

Installation of TI-500 RF digital indicator

Find a suitable location for the indicator and use the included bracket to mount the unit to a wall or table. Use this handy guide for mounting the bracket to a wall or table:

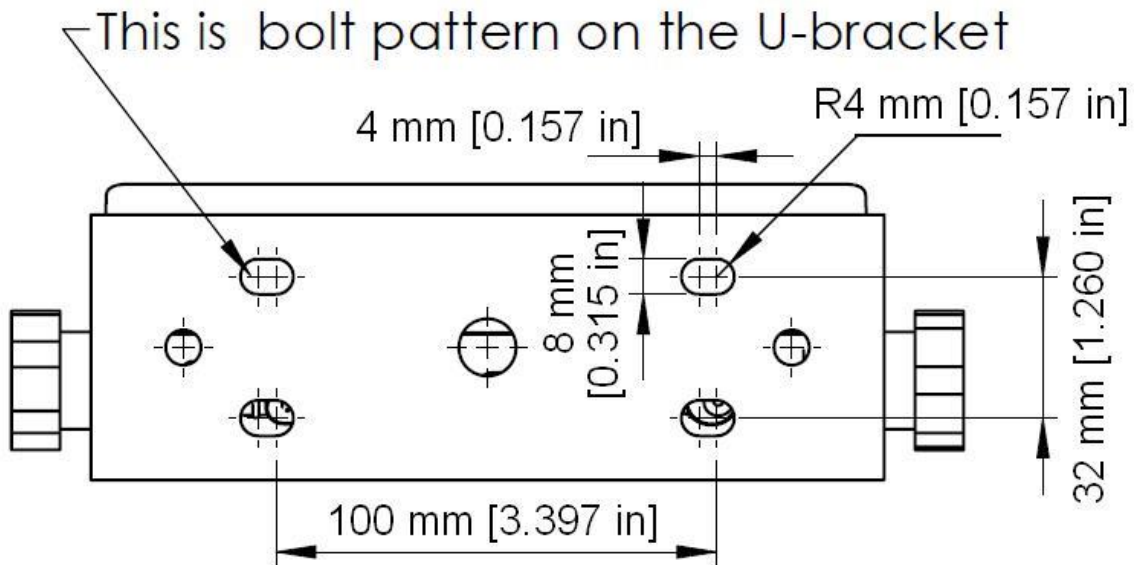

The TI-500 RF digital indicator 4-AA batteries to operate (not included). To install the batteries, remove the plastic battery cover from the rear panel. Observe proper direction (polarity) of the batteries. Replace the battery cover.

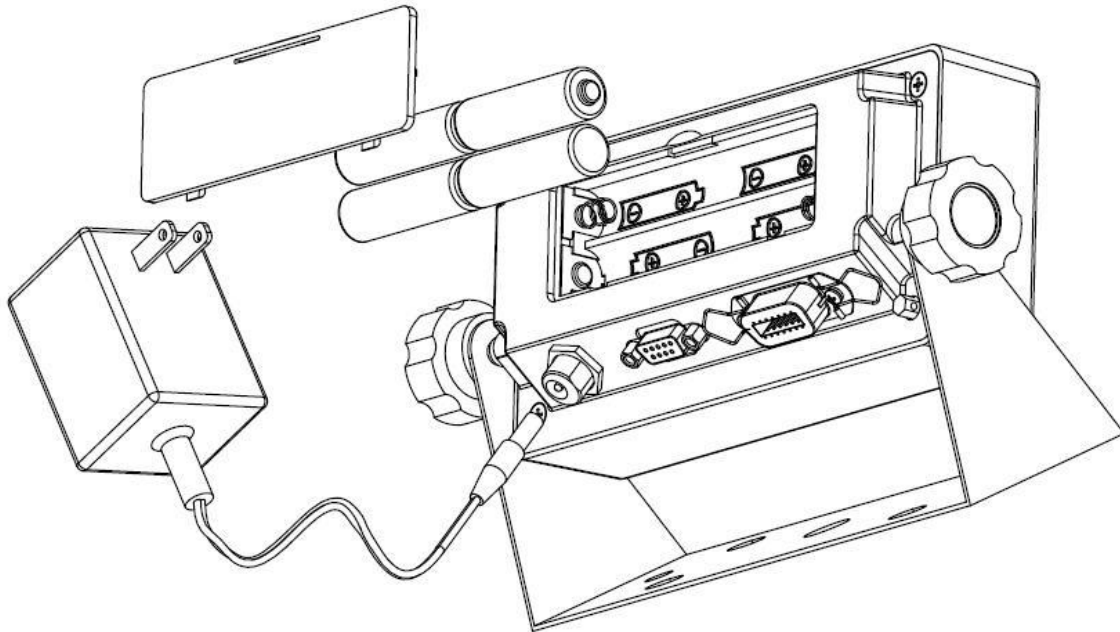

The TI-500 RF digital indicator may also be powered by the AC wall adaptor included with the kit.

The TI-500 RF digital indicator features one full duplex RS-232 serial port, designed for connection to a computer or a serial printer. The same port may be also used as a simplex, RS-232 port designed for connection to a remote display.

DSUB9 Connector

Pin No.	Wire Name
2	RXD
3	TXD
5	Ground

Installation of TI-500 RF SS digital indicator

Find a suitable location for the indicator and use the included bracket to mount the unit to a wall or table. Use this handy guide for mounting the bracket to a wall or table:

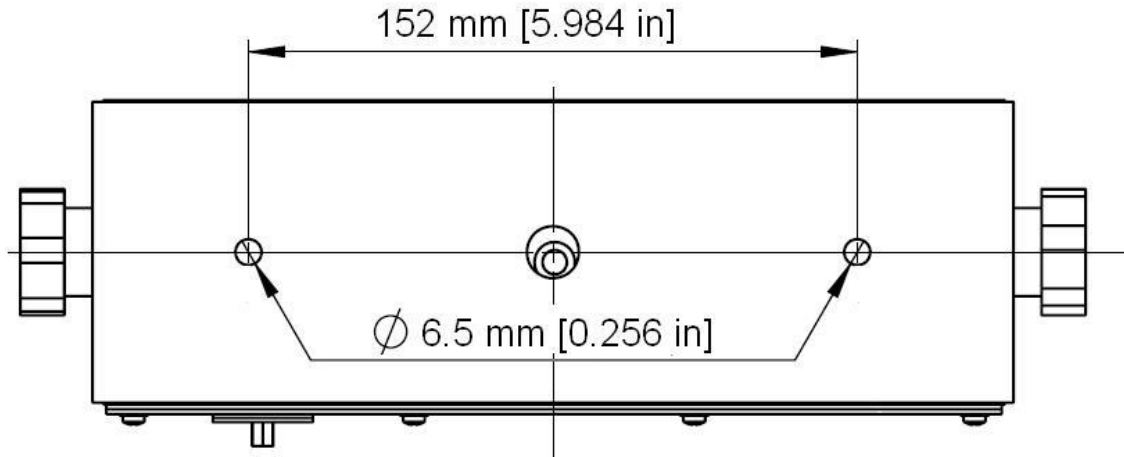

The TI-500 RF SS digital indicator contains an internal lead-acid rechargeable battery. Before using the indicator for the first time, please charge the battery overnight. The battery can be charged while ON or OFF and the indicator can be operated while it's charging unless the state of charge is very low.

CONNECTIONS

The rear cover must first be removed to make the appropriate connections to the weigh platform, printer, remote display and power supply. To remove the rear cover, simply remove the screws that secure it to the enclosure and set aside.

Caution! Disconnect power source from indicator prior to removing rear cover.

Caution! Disconnect leads from rechargeable battery to avoid shorts!

CONNECTING THE WEIGH PLATFORM

The TI-500 RF SS indicator contains a connection terminal on the main board for connection to the load cell cable. Connect your shielded load cell cable (not included) to the appropriate terminal on the main board. **NOTE:** Be sure to set parameter F11 for 4 or 6 wires as needed.

Load Cell Terminal (J3)

Name	Function		Name	Function
-EX	- Excitation		S+	+ Sense
S-	- Sense		+EX	+ Excitation
IN-	- Signal		SH	Shield
IN+	+ Signal			

CONNECTING THE SERIAL I/O DEVICE

The TI-500 RF SS model comes standard with one full duplex RS-232 serial port, designed for connection to a computer or a serial printer. The same port may be also used as a simplex, RS-232 port designed for connection to a remote display.

Connection assignments for all serial RS-232 communication terminals on the TI-500 RF are shown below.

RS-232 Communication Terminal (J6)

Pin #	Function		Pin #	Function
1	RXD		4	RTS
2	TXD		5	CTS
3	Gnd			

Installation of TI-500 RFTM remote wireless A/D Module

Physical installation

The remote wireless A/D module is designed to fit into a pre-defined opening:

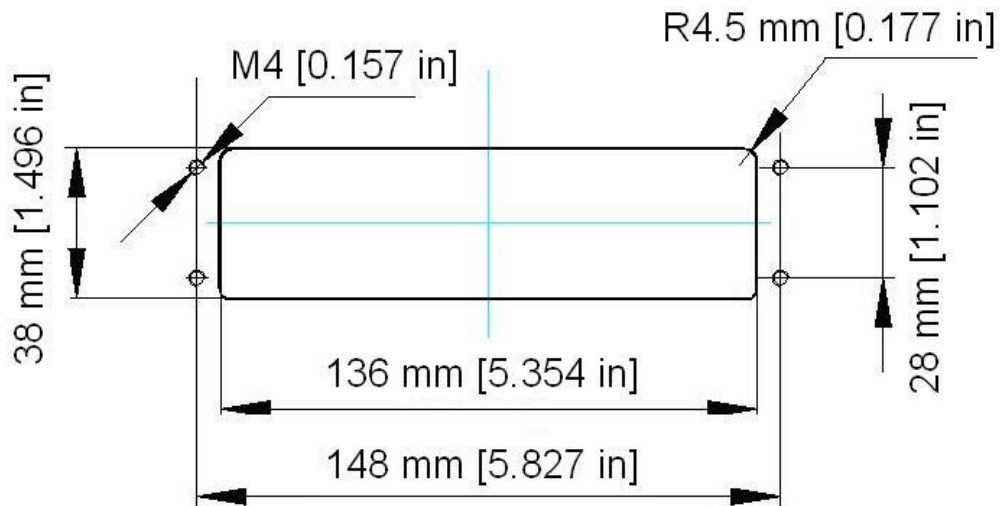

An optional mounting bracket is also available.

Electrical Connections

The TI-500 RFTM module requires an external 6VDC power supply. Single channel units require about 60 mA of current to drive four 350-ohm load cells (20 mA plus 10 mA per load cell). Dual channel units require about 100 mA of current to drive eight 350-ohm load cells.

The TI-500 RFTM module will operate normally down to approximately 4 VDC whereupon it will indicate a low battery condition.

The power leads are pre-wired to the inside of the RFTM. The red lead goes to the positive DC terminal while the black lead goes to the negative DC terminal.

The TI-500 RFTM module also has at least one load cell input terminal or wiring harness. Each terminal or harness can drive up to four 350-ohm load cells. The terminals are spring loaded; to open, use a small screwdriver to press down on the orange tab. The harnesses should be spliced to the load cell or j-box using the supplied butt splices.

Load Cell Input Terminal

Marking	Wire Name	Marking	Wire Name
S-	- Signal	E-	- Excitation
S+	+ Signal	E+	+ Excitation

NOTE: On dual TI-500 RFTM modules, each load cell terminal is marked 1-4, e.g. L/C3.

Load Cell Input Harness

Wire Color	Wire Name	Wire Color	Wire Name
White	- Signal	Black	- Excitation
Green	+ Signal	Red	+ Excitation

Installation of LCT-1 remote wireless digital junction box

Physical installation

Find a suitable location for the digital junction box and use the mounting tabs to mount the unit to a wall or table. The junction box may be mounted vertically or horizontally. Use this handy guide for mounting the box to a wall or table:

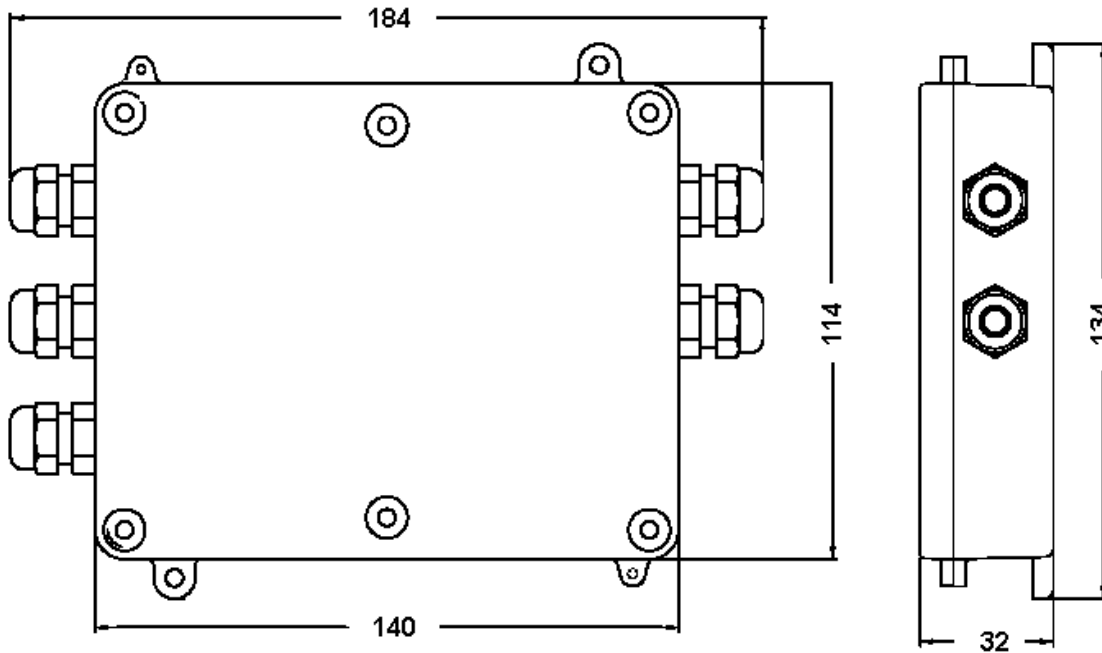

Electrical Connections

The top cover must first be removed to make the appropriate connections to the weigh platform. To remove the top cover, simply remove the six (6) screws that secure it to the enclosure and set aside.

Caution! Disconnect power source from junction box prior to removing top cover.

Note: If the optional control panel was ordered, you need not make connections to the LCT-1 for power supply, serial device or on/off control

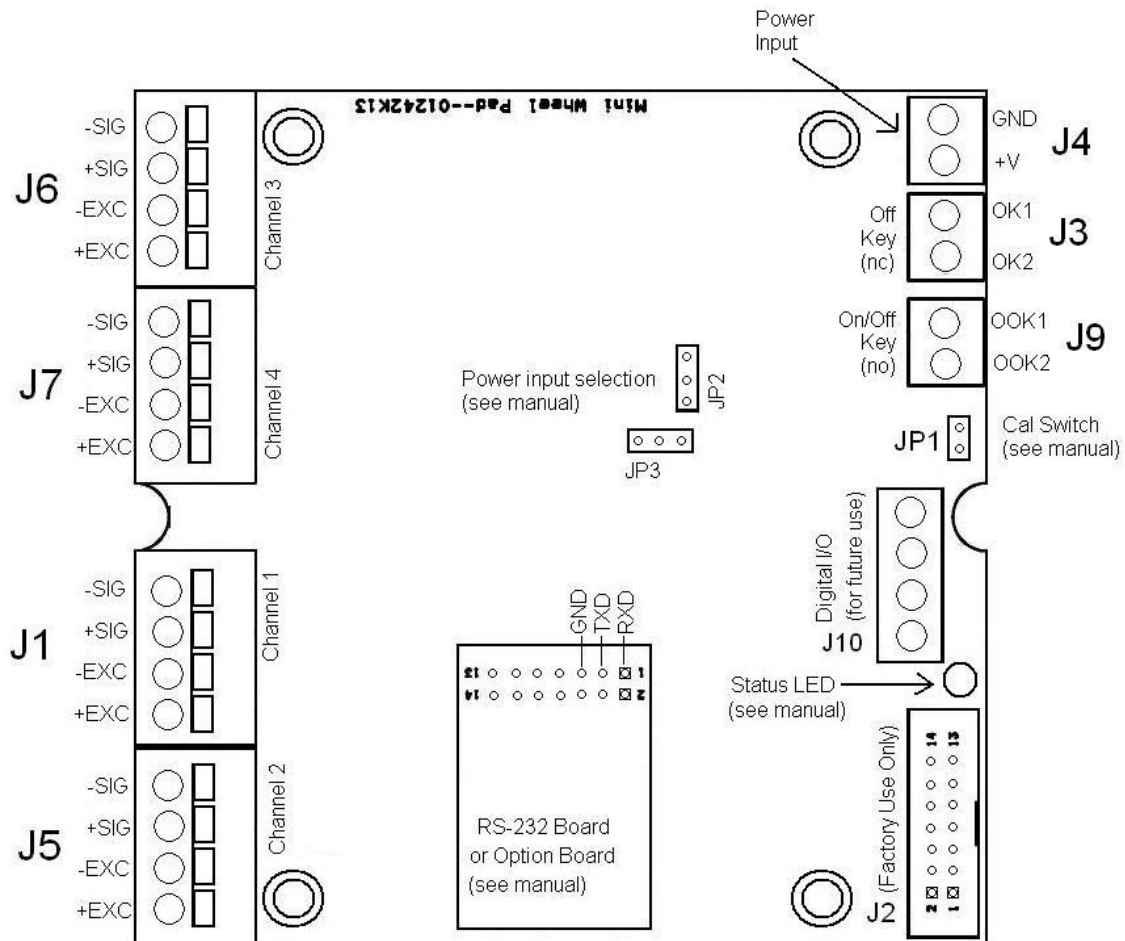

Connecting your load cell(s)

The LCT-1 contains four connection terminals on the main board – one for each load cell:

1. LC1: J1
2. LC2: J5
3. LC3: J6
4. LC4: J7

Connect your load cell cable (not included) to the appropriate terminal on the main board.

Caution! Strip each load cell wire back 10 mm and tin before inserting into the spring-loaded terminals.

Load Cell Terminals (J1, J5, J6 and J7)

Label	Function
S-	- Signal
S+	+ Signal
E-	- Excitation
E+	+ Excitation

Caution! If connecting less than four load cells to the LCT-1, then the S+ and S- terminals **must be shunted with a jumper wire** on each unused load cell input terminal

Getting Started – Cabled Systems

1. Press and hold the ON/PRINT key on the digital indicator unit for two seconds. After a brief initialization period, the scale will revert to a zero ("0") weight display.

Your digital indicator is now ready for configuration and system calibration.

Getting Started – Wireless Systems

1. Switch on the TI-500 RFTM remote wireless A/D module(s) by pressing the BLUE button once. The blue LED will turn solid for a few seconds and then start to flash.
2. Next press and hold the ON/PRINT key on the digital indicator unit for two seconds. After a brief initialization period, the scale will revert to a zero ("0") weight display.

Your wireless digital indicator is now ready for configuration and system calibration.

SYSTEM CONFIGURATION

Configuration Menus

The RF digital indicator contains three menus to configure the scale system:

Setup (“F”) Menu – Configures all scale-related parameters including calibration procedures.

User (“A”) Menu – Configures COM2 communication parameters and other misc. parameters, e.g. automatic turn off and hold mode.

COM1 (“C”) Menu – Configures COM1 communication parameters. **NOTE:** This menu will not appear for wireless systems (see F29).

Bluetooth (“B”) Menu – Configures all parameters relating to the RF weighing module(s). **NOTE:** This menu will not appear for cabled systems (see F29).

The configuration menus are laid out in the following vertical arrangement:

- Top [Menu selection] level
- Parameter level
- Selection level (or function level, e.g. span calibration)

Please review the following chart to get a feel for how to navigate among the various menus and parameters.

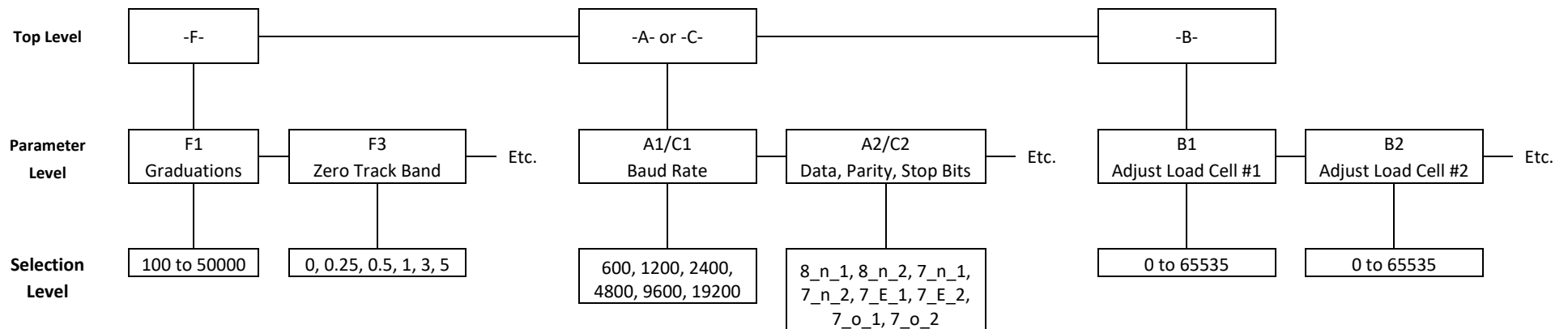

NOTE: The -C- menu appears in place of the -B- menu for cabled systems.

Entering the Setup (“F”) Configuration Menu

To access this menu, please follow these directions:

1. Switch off the RF digital indicator by pressing and holding down the ZERO/OFF key for about 5 seconds.
2. Press and hold down the ON/PRINT key (about 20 seconds) until the screen shows “-F-”.
3. Scroll down using the ZERO/OFF (down) key to reach the parameter level. The scale shows “F 1”.
4. Move from one “F” menu parameter to the next by using the TARE (left) or ON/PRINT (right) keys. For example, to go from F1 to F2, press the ON/PRINT key. To go from F2 back to F1, press the TARE key.
5. Once you have arrived at the proper “F” menu parameter, e.g. “F 1”, press the ZERO/OFF (down) key once to arrive at the selection level. The scale displays the current parameter setting.
6. To scroll thru the available parameter settings, use the TARE (left) or ON/PRINT (right) keys.
7. Once the setting you want is displayed on the screen, press the NET/GROSS (set) key to save this value and revert up to the parameter level, e.g. “F 1”.
8. To save all parameter settings, it is imperative to exit all menus in the following manner: At the parameter level, press the UNITS (up) key twice (two times) to exit the Setup Menu. The indicator displays ‘SAVe’ and then automatically powers off.

Setup (“F”) Menu Descriptions

This section provides more detailed descriptions of the selections found in the Setup Menu Chart. Factory-set defaults are shown in **bold** with a checkmark; (√).

CODE/NAME	DESCRIPTION	SELECTION LIST
F1 Graduations	Specifies number of full-scale graduations, i.e. capacity / division. Value should be consistent with legal regulations and environmental limits on the useful system resolution. Pressing the ZERO key to scroll down one level begins the sequence.	Key-in 100 - 50000 10000 √
F2 Sampling Rate	Sets the sampling rate in Hertz (measurements per second). Use 10 Hz for most applications or 80 Hz for extra fast response time NOTE: This menu is not applicable to wireless systems	10 √ 80
F3 Zero Track Band	Selects the range within which the scale will automatically zero. Note that the scale must be in standstill to automatically zero. Selections are in display divisions (d).	oFF 0.25 0.5 √ 1 3 5
F4 Zero Range	Selects the range within which the scale will accept a front panel ZERO command. Note that the scale must be in standstill to automatically zero. Selections are in display % of full scale. Pressing the ZERO key to scroll down one level begins the sequence.	Key-in 0 - 100 100 √

CODE/NAME	DESCRIPTION	SELECTION LIST
F5 Motion Band	Sets the level at which motion is detected. If motion is not detected, the scale can process a Print or Zero command. Maximum value varies depending on local regulations. Expressed as scale divisions per second (d/s).	oFF 0.5 1√ 2 4 8 16 32
F6 ⁽¹⁾ Digital Filter	Averages weight readings to produce higher stability. Choose the speed that works best for your application. "FAST" = Fast "nnEd" = Medium "SLo" = Slow	FAST nnEd √ SLo
F7 Overload Limit	Selects the desired formula which determines the point at which the indicator shows overload. All selections are based on the primary unit selected in F8. "FS" = Full Scale capacity "FS 2" = Full Scale + 2% "FS 5" = Full Scale + 5% "FS 1d" = Full Scale + 1d "FS 9d" = Full Scale + 9d	FS FS 2√ FS 5 FS 1d FS 9d
F8 Calibration Unit	Selects the primary base unit to be used in the calibration process. Also, the default unit for normal operation. "1" = primary unit is lb "2" = primary unit is in kg "3" = primary unit is oz "4" = primary unit is in g	1√ 2 3 4
F9 ⁽²⁾ Display Divisions	Determines the desired weight increments. Value should be consistent with legal requirements.	1√ 2 5
F10 ⁽²⁾ Decimal Pt.	Determines location of the decimal point.	0√ 0.0 0.00 0.000 0.0000 00
F11 No. of L/C wires	Selects the number of wires on the load cell(s) to be connected to the indicator. Cabled systems only. "4" = four wires "6" = six wires (SENSE)	4√ 6
F12 Percentage Hold Weight	Allows you to select the percentage (of the displayed held value) of weight change before the scale automatically unlocks the held weight and relocks onto the new weight.	5 10√ 20 50 75 100
F13 Gravity (g)	Allows you to select the gravity (g) of the location of the scale system. Expressed in m/s ² . Pressing the ZERO key to scroll down one level begins the sequence.	Key-in 9.750 to 9.850 9.797√
F14 Power-on zero (IZSM)	Allows you to enable or disable power-on zero. (IZSM) "yES" = IZSM is enabled "no" = IZSM is disabled	yES√ no

Footnotes:

- (1) On older units, the selection list ranged from 0 to 12 with a default setting of 8.
- (2) On older units, there was no F10 menu; the display size was programmed thru F9 and the selection list was 0.05, 0.1, 0.2, 0.5, 1, 2, 5, 10, 20 and 50.

CODE/NAME	DESCRIPTION	SELECTION LIST
F16 Zero Calibration	Places indicator into the zero-calibration routine. Scrolling down with the ZERO key one level begins the procedure.	Press ZERO key to begin sequence
F17 Span Calibration	Places indicator into the span calibration routine. Scrolling down with the ZERO key one level begins the procedure.	Press ZERO key to begin sequence
F18 View Calibration	Actuates the function that allows you to view both the zero and span calibration value. The values displayed in this function are valid only after Calibration (F16 & F17) has been successfully completed. Scrolling down with the ZERO key one level begins the procedure.	Press ZERO key to begin sequence
F19 Key-in Zero	Allows you to key-in known zero calibration value in case of memory loss in the field. Scrolling down with the ZERO key one level begins the procedure.	Press ZERO key to begin sequence
F20 Key-in Span	Allows you to key-in a known span calibration value in case of memory loss in the field. Scrolling down with the ZERO key one level begins the procedure.	Press ZERO key to begin sequence
F21 Factory Reset (US)	This sub-menu will reset all parameters in the "F" and "A" menu to the default settings. It will not overwrite any previously saved calibration data. USE WITH CAUTION!	Press the ZERO key twice to execute
F22 Factory Reset (EU)	This sub-menu will reset all parameters in the "F" and "A" menu to the default settings. It will not overwrite any previously saved calibration data. USE WITH CAUTION!	Press the ZERO key twice to execute
F23 Full Factory Reset	This sub-menu will reset all system parameters to the default settings. It will not overwrite any previously saved calibration data. USE WITH EXTREME CAUTION!	Press the ZERO key twice to execute
F24 Fine Tune 4-20 mA	Actuates the function that allows you to fine-tune the optional 4-20 mA analog output. Pressing the ZERO key to scroll down one level begins the sequence.	Press the ZERO key to begin sequence
F25 Set Point Function	Selects the number of function of the set points and relay outputs. See user's guide for definitions	0 to 10 0 ✓
F26 (1) Lower Threshold Weight - Auto Accumulate	Selects the weight below which the auto-accumulate function will re-arm itself. Key-in the weight value (in the primary unit). Scrolling down with the ZERO key one level begins the procedure. "0" = Disabled (manual accumulate)	Key-in 0 - 999999 0 ✓
F27 (1) Upper Threshold Weight - Auto Accumulate	Selects the weight above which the auto-accumulate function will re-arm itself. Key-in the weight value (in the primary unit). Scrolling down with the ZERO key one level begins the procedure. "0" = Disabled (manual accumulate)	Key-in 0 - 999999 0 ✓

¹ When F26 and F27 are set to zero (default) then the accumulate function will work manually. When these two parameters are set to non-zero values, then the accumulate function will operate automatically. F30 = 1 is the 'master' setting to turn the accumulator ON

CODE/NAME	DESCRIPTION	SELECTION LIST
F29 Load Cell Input	Selects the load cell input source. <p style="text-align: center;">“AdC” = Internal A/D (cabled), “1rAdlo” = One external wireless A/D module, “2rAdlo” = Two external wireless A/D modules “4 AdC” = JB Digital Series</p>	AdC √ 1rAdlo 2rAdlo 4 AdC
F30 Special Appli- cation	Used to select one special application feature, subject to local legal requirements. <p style="text-align: center;">“0” = None (Gross/Net), “1” = Accumulator, “2” = Remote Display, “3” = Piece Count, “5” = Hold, “6” = Set Point</p>	0 √ 1 2 3 5 6
F31 Gross Zero Band	Selects the range within which the scale will automatically clear the tare and switch to Gross mode. Note that the scale must be in standstill. Selections are in display divisions (d). Scrolling down with the ZERO key one level begins the procedure. <p style="text-align: center;">“0” = Disabled</p>	Key-in 0 - 10 0 √
F32 Center of Zero Band	Selects the range around gross zero within which the scale will display the Center of Zero annunciator. Selections are in display divisions (d).	0.25 √ 0.5
F34 Auto Print Min. Weight	Selects the minimum weight at which the auto print function will work if enabled. Selections are in display divisions (d). Scrolling down with the ZERO key one level begins the procedure. <p style="text-align: center;">“0” = Disabled</p>	Key-in 0 - 100 1 √

Entering the User (“A”) or COM (“C”) Menu

NOTE: Follow the same steps to enter the COM (“C”) Menu— just substitute “C” for “A” below

1. Switch off the RF digital indicator by pressing and holding down the ZERO/OFF key for about 5 seconds.
2. Press and hold down the ON/PRINT key (about 20 seconds) until the screen shows “-F-”.
3. Press the ON/PRINT (right) key once. The screen displays “-A-”.
4. Scroll down using the ZERO/OFF (down) key to reach the parameter level. The scale shows “A 1”.
5. Move from one “A” parameter to the next by using the TARE (left) or ON/PRINT (right) keys. For example, to go from A1 to A2, press the ON/PRINT key. To go from A2 back to A1, press the TARE key.
6. Once you have arrived at the proper “A” menu parameter, e.g. “A 1”, press the ZERO/OFF (down) key once to arrive at the selection level. The scale displays the current parameter setting.
7. To scroll thru the available parameter settings, use the TARE (left) or ON/PRINT (right) keys.
8. Once the setting you want is displayed on the screen, press the NET/GROSS (set) key to save this value and revert up to the parameter level, e.g. “A 1”.

9. To save all parameter settings, it is imperative to exit all menus in the following manner: At the parameter level, press the UNITS (up) key twice (two times) to exit the User Menu. The indicator displays 'SAVe' and then automatically powers off.

User ("A") and COM ("C") Menu Descriptions

This section provides more detailed descriptions of the selections found in the User Menu Chart. Factory-set defaults are shown in **bold** with a checkmark; (✓).

CODE/NAME	DESCRIPTION	SELECTION LIST
A1/C1 ⁽²⁾ Baud Rate	Selects the baud rate for data transmission through the serial port.	600, 1200, 2400, 4800, 9600 ✓, 19200, 38400, 57600, 115200
A2/C2 Data Bits, Parity and Stop Bits	Selects the number of data bits and parity of serial transmission. "8_n_1" = 8 data bits with no parity bit and one stop bit "8_n_2" = 8 data bits with no parity bit and two stop bits "7_n_1" = 7 data bits with no parity bit and one stop bit "7_n_2" = 7 data bits with no parity bit and two stop bits "7_E_1" = 7 data bits with even parity bit and one stop bit "7_E_2" = 7 data bits with even parity bit and two stop bits "7_o_1" = 7 data bits with odd parity bit and one stop bit "7_o_2" = 7 data bits with odd parity bit and two stop bits	8_n_1 ✓ 8_n_2 7_n_1 7_n_2 7_E_1 7_E_2 7_o_1 7_o_2
A3/C3 Serial Port Mode	Selects the mode of the serial port: Refer to Appendix B for more information. "0" = Demand Full Duplex "1" = Continuous Full Duplex "2" = Auto Print "3" = RFID "4" = Test and Measurement "5" = configure analog option card to 4-20 mA "6" = configure analog option card to 0-10 V	0 ✓ 1 2 3 4 5 (A3 only) 6 (A3 only)
A4 MP-20 Print Header	Tells MP-20 printer to print the header information. Valid only when A6 is set to "2" or "4". "0" = Do NOT Print Header "1" = Print Header	0 ✓ 1
A5 Units Key	Selects function of the Units key. NOTE: The UNITS key will not function if ounces or grams are selected for F8. "no" = Disabled "yES" = Enabled	no yES ✓
A6/C6 Output String	Selects fixed output string for serial port. Refer to Appendix B for details. "0" = String Format 1 (Condec Demand) "1" = String Format 2 (Condec Continuous) "2" = Text Print Ticket "3" = Text Print Ticket with MP-20 Auto Label Feed "4" = Cardinal 190 Scoreboard emulation (³)	0 ✓ (A6) 1 2 ✓ (C6) 3 4

² On older units, the selection list stopped at 38400

CODE/NAME	DESCRIPTION	SELECTION LIST
A7 ID Number	Selects the ID number mode. "no" = Disabled "yES" = Enabled	no√ yES
A8 Set ID Number	Allows you to key-in the ID number. Pressing the ZERO key to scroll down one level begins the sequence.	Key-in 0 to 999999 123456 √
A9/C9 Line Feeds	Allows you to key-in the number of line feeds. Pressing the ZERO key to scroll down one level begins the sequence.	Key-in 0 to 99 8 √
A10 Auto Power Off - Digital Indicator	Allows you to configure the automatic power off time for the digital indicator. Expressed in minutes of inactivity (keys and weighing platform). Pressing the ZERO key to scroll down one level begins the sequence.	Key-in 0 to 30 5 √
A11 Hold Mode	This mode of operation is enabled by setting F30 to "5". This mode captures the weight of an unstable load, e.g. livestock, by freezing the weight on the display. Use the Motion Band setting (F5) and the Percentage Hold setting (F12) to adjust this mode to your specific application. When the weight has been locked onto the display, two arrows beneath the weight display will be turned ON. "0" = Off AUTOMATIC (A11 = 1) – Automatically locks weight on the display when stable. If the weight of the object on the scale changes by the F12 setting (e.g. 10%) then the sale unlocks the held reading and relocks onto the new weight. This occurs during both increasing and decreasing weight values. MANUAL (A11 = 2) – Press the NET/GROSS key <u>before</u> applying any weight to the scale. After the load has stabilized, the display will hold the weight reading on the screen until the NET/GROSS key is pressed again. If the weight of the object on the scale changes by the F12 setting (e.g. 10%) then the sale unlocks the held reading and relocks onto the new weight. This occurs during increasing weight values only. PEAK HOLD (A11 = 3) – The display updates as the load increases but not as the load decreases. The value shown on the screen is the maximum weight applied to the scale. Press the UNITS key to toggle between live mode and peak hold mode. The 'P' annunciator is used to indicate that you are in Peak Hold mode. When you exit out of peak hold mode, the old peak value is automatically cleared.	0 √ 1 2 3
A12 Backlight Brightness	Selects the brightness of the LCD backlight. Selections are in % of full brightness.	0 (Off) 20 50 75 100 √
A13/C13 Handshaking	Selects function of the hardware handshaking. (NOTE: Receive pin is used for handshaking). "0" = Disabled "1" = Enabled	0 √ 1

³ A1/C1 (baud rate) must be set to "19200"

CODE/NAME	DESCRIPTION	SELECTION LIST
A18 Date	Selects function of the printed date. "no" = Disabled "yES" = Enabled	no√ yES
A19 Date Format	Selects the printed format for date. "USA" = mm/dd/yy "IntL" = dd/mm/yy	USA√ IntL
A20 Set System Time & Date	Allows you to set the system time and date. Pressing the ZERO key to scroll down one level begins the sequence.	Press ZERO key to begin sequence
A22 Low Battery Auto Power Off - Digital Indicator	Allows you to configure the automatic power off time of the indicator after it enters a low battery condition. Expressed in minutes. Pressing the ZERO key to scroll down one level begins the sequence.	Key-in 0 to 99 2√
A23 Audible Key Feedback	Selects function of the audible key feedback (beeper). "no" = Disabled "yES" = Enabled	no yES√
A24 Diagnostics	Used to access the listed test functions (one at a time). Pressing the ZERO key begins the sequence. "A24-U1" = Display segment test, "A24-U2" = A/D converter test, "A24-U3" = Input test, "A24-U4" = Output test (all) "A24-U5" = Serial Port test (both), "A24-U6" = Keyboard test "A24-U7" NTEP test mode	Press ZERO key to begin sequence
A25 Decimal Point	Selects printed (not displayed) decimal point character. "0" = Period ('.') "1" = Comma (',')	0√ 1
A26 Remote Keyboard	Allows the keyboard of the remote display to operate the indicator. Only works with a Transcell TI500 RF set to operate in remote display emulation mode. "no" = Disabled "yES" = Enabled	no√ yES
A30 Upload EID Database	Actuates the function which transmits the EID database information to all serial ports configured for RFID serial port mode (A3/C3).	Press ZERO key to begin sequence
A31 Clear EID database	Allows you to clear the stored EID database.	Press ZERO key to begin sequence
A32 Assign remote key #1	Allows you to assign any one of the front panel keys to the digital I/O board input #1 for remote control / input. Not active currently.	0√ 1 2 3 4 5
A33 Assign remote key #2	Allows you to assign any one of the front panel keys to the digital I/O board input #2 for remote control / input. Not active currently.	0√ 1 2 3 4 5

CODE/NAME	DESCRIPTION	SELECTION LIST
A34 Correction Sensor Setting	Correction sensor setting. "0" = Disable Angle Sensor "1" = Compensation with no Angle Limits "2" = Compensation with NTEP Limits	0 ✓ 1 2

Setting system time and date (A20)

1. Switch off the RF digital indicator by pressing and holding down the ZERO/OFF key for about 5 seconds.
2. Press and hold down the ON/PRINT key (about 20 seconds) until the screen shows "-F-".
3. Press the ON/PRINT (right) key once. The screen displays "-A-".
4. Scroll down using the ZERO/OFF (down) key to reach the parameter level. The scale shows "A 1".
5. Move from A1 to A20 by pressing the TARE (left) key repeatedly until the screen shows "A 20".
6. Once you have arrived at A20 press the ZERO/OFF (down) key once. The screen displays "ho_xx" where 'xx' is the current hour, e.g. "15". One digit will be flashing.
7. Use the four directional keys to adjust the displayed value to the actual hour value. Increase the flashing digit by pressing the UNITS key. Decrease the flashing digit by pressing the ZERO/OFF key. Pressing the TARE key or the ON/PRINT key will change the position of the flashing digit.
8. After entering the exact value, press the NET/GROSS key to save the value. The screen displays "n_xx" where 'xx' is the current minute, e.g. "55". One digit will be flashing.
9. Use the four directional keys to adjust the displayed value to the actual minute value. Increase the flashing digit by pressing the UNITS key. Decrease the flashing digit by pressing the ZERO/OFF key. Pressing the TARE key or the ON/PRINT key will change the position of the flashing digit.
10. After entering the exact value, press the NET/GROSS key to save the value. The screen displays "dA_xx" where 'xx' is the current day of the month, e.g. "14". One digit will be flashing.
11. Use the four directional keys to adjust the displayed value to the actual day value. Increase the flashing digit by pressing the UNITS key. Decrease the flashing digit by pressing the ZERO/OFF key. Pressing the TARE key or the ON/PRINT key will change the position of the flashing digit.
12. After entering the exact value, press the NET/GROSS key to save the value. The screen displays "n_xx" where 'xx' is the current month of the year, e.g. "02". One digit will be flashing.
13. Use the four directional keys to adjust the displayed value to the actual month value. Increase the flashing digit by pressing the UNITS key. Decrease the flashing digit by pressing the ZERO/OFF key. Pressing the TARE key or the ON/PRINT key will change the position of the flashing digit.

14. After entering the exact value, press the NET/GROSS key to save the value. The screen displays “yE_xx” where ‘xx’ is the current month of the year, e.g. “11”. One digit will be flashing.
15. Use the four directional keys to adjust the displayed value to the actual year value. Increase the flashing digit by pressing the UNITS key. Decrease the flashing digit by pressing the ZERO/OFF key. Pressing the TARE key or the ON/PRINT key will change the position of the flashing digit.
16. After entering the exact value, press the NET/GROSS key to save the value and revert up to the parameter level, e.g. "A 20".
17. To save all parameter settings, it is imperative to exit all menus in the following manner: At the parameter level, press the UNITS (up) key twice (two times) to exit the User Menu. The indicator displays 'SAVE' and then automatically powers off.

Diagnostics (A24)

Here is a brief description of each test mode:

A24-U1 Display Test – Lights up all display segments, counting down from 666666 to 11111. Test ends automatically when complete.

A24-U2 ADC Test – Shows internal A/D converter counts – useful for troubleshooting weighing issues. End test manually by pressing the MODE (Set) key.

A24-U3 Input Test – Displays input logic (0 or 1) of input terminal. “0” mean input pin is grounded; “1” means input pin is open. End test manually by pressing the MODE (Set) key.

A24-U4 Output Test – Sets all output pins ‘ON’. End test manually by pressing the MODE (Set) key.

A24-U5 Serial Test – Transmits a data string continuously out both serial ports (“TEST1” on COM1 and “TEST2” on COM2). End test manually by pressing the MODE (Set) key.

A24-U6 Keyboard Test – Displays a keycode for each key pressed on the keypad. See Table below. End test manually by pressing the MODE (Set) key.

Key	Keycode
Units	1
Zero	2
Net/Gross	3
Tare	4
Print	5

A24-U7 NTEP Mode – This is a special mode which automatically disables zero tracking and automatic shut off; only the ZERO key can function in this mode. End test manually by pressing the MODE (Set) key.

Entering the Bluetooth (“B”) Menu

NOTE: This menu applies to remote wireless A/D systems only (see F29)

1. Switch off the display unit by pressing and holding down the ZERO/OFF key for about 5 seconds.
2. Press and hold down the ON/PRINT key (about 20 seconds) until the screen shows “-F-”.
3. Press the ON/PRINT key until the screen displays “-B-”.
4. Scroll down using the ZERO/OFF (down) key to reach the parameter level. The scale shows “B 1”.
5. Move from one “B” parameter to the next by using the TARE (left) or ON/PRINT (right) keys. For example, to go from B1 to B2, press the ON/PRINT key. To go from B2 back to B1, press the TARE key.
6. Once you have arrived at the proper “B” menu parameter, e.g. ”B 1”, press the ZERO/OFF (down) key once to arrive at the selection level. The scale displays the current parameter setting.
7. To scroll thru the available parameter settings, use the TARE (left) or ON/PRINT (right) keys.
8. Once the setting you want is displayed on the screen, press the NET/GROSS (set) key to save this value and revert up to the parameter level, e.g. ”B 1”.
9. To save all parameter settings, it is imperative to exit all menus in the following manner: At the parameter level, press the UNITS (up) key twice (two times) to exit the Bluetooth Menu. The indicator displays ‘SAVe’ and then automatically powers off.

Bluetooth (“B”) Menu Descriptions

This section provides more detailed descriptions of the selections found in the Bluetooth Menu Chart. Factory-set defaults are shown in **bold** with a checkmark; (✓).

CODE/NAME	DESCRIPTION	SELECTION LIST
B1 Adjust Load Cell (Corner) #1 Factor	This parameter allows you to adjust (‘tweak’) the digital corner compensation factory for load cell/corner #1. Be sure to perform a digital corner calibration (via B10) before using this procedure. Pressing the ZERO key to scroll down one level begins the programming sequence.	Key-in 0 to 6.5535 1.0000 ✓
B2 Adjust Load Cell (Corner) #2 Factor	This parameter allows you to adjust (‘tweak’) the digital corner compensation factory for load cell/corner #2. Be sure to perform a digital corner calibration (via B10) before using this procedure. Pressing the ZERO key to scroll down one level begins the programming sequence.	Key-in 0 to 6.5535 1.0000 ✓
B3 Adjust Load Cell (Corner) #3 Factor	This parameter allows you to adjust (‘tweak’) the digital corner compensation factory for load cell/corner #3. Be sure to perform a digital corner calibration (via B10) before using this procedure. Pressing the ZERO key to scroll down one level begins the programming sequence.	Key-in 0 to 6.5535 1.0000 ✓

CODE/NAME	DESCRIPTION	SELECTION LIST
B4 Adjust Load Cell (Corner) #4 Factor	This parameter allows you to adjust ('tweak') the digital corner compensation factory for load cell/corner #4. Be sure to perform a digital corner calibration (via B10) before using this procedure. Pressing the ZERO key to scroll down one level begins the programming sequence.	Key-in 0 to 6.5535 1.0000 √
B6 Restore factory calibration	Restores factory calibration data. Scrolling down with the ZERO key one level begins the procedure.	Press ZERO key to begin sequence
B8 Auto Power Off - RFTM	This parameter allows you to set the automatic power off time in minutes for the TI-500 RFTM. "0" = Always on "1" = 30 minutes "2" = 1 hour "3" = 2 hours	0 1 2 3 √
B9 Low Battery Force Off - RFTM	This parameter allows you to set the automatic power off time in minutes for the TI-500 RFTM during a low battery condition. Pressing the ZERO key to scroll down one level begins the programming sequence.	Key-in 0 to 99 10 √
B10 Digital Corner Calibration	Places indicator into the digital corner calibration routine. Scrolling down with the ZERO key one level begins the procedure.	Press ZERO key to begin sequence
B11 Pair Bluetooth Radios	Allows a replacement RFTM/DJB to be paired with the RF indicator in case of a field replacement. Scrolling down with the ZERO key one level begins the procedure.	Press ZERO key to begin sequence

Bluetooth Pair Procedure (B11)

NOTE 1: Before starting it is imperative to power off all RFTM's within 1 kilometer (~3280 feet)

NOTE 2: This procedure is used to configure up to two RFTM's (BT1 and BT2). If you have only one RFTM, then just press the NET/GROSS key (i.e. enter "000000") when prompted for the second one (Step #9)

NOTE 3: Before starting, find the MAC address printed on the side of the RFTM and write down or make note of the last six digits. For example, if the MAC address is 0080986FC492 then the value we want to enter is 6FC492

NOTE 4: The MAC address is hexadecimal meaning that each 'digit' will range from 0 to F instead of from 0 to 9.

1. Switch off the RF digital indicator by pressing and holding down the ZERO/OFF key for about 5 seconds or until you hear a double beep and the screen shows "oFF".
2. Press and hold down the ON/PRINT key (about 20 seconds) until the screen shows "-F-".
3. Press the ON/PRINT (right) key once. The screen displays "-B-".
4. Scroll down using the ZERO/OFF (down) key to reach the parameter level. The scale shows "B 1".
5. Move from B1 to B11 by pressing the TARE (left) key once or until the screen shows "B 11".

6. Use the four directional keys to adjust the displayed value to the actual day value. Increase the flashing digit by pressing the UNITS key. Decrease the flashing digit by pressing the ZERO/OFF key. Pressing the TARE key or the ON/PRINT key will change the position of the flashing digit.
7. After entering the exact value, press the NET/GROSS key to save the value. The screen displays "n→_xx" where 'xx' is the current month of the year, e.g. "02". One digit will be flashing.
8. Use the four directional keys to adjust the displayed value to the actual month value. Increase the flashing digit by pressing the UNITS key. Decrease the flashing digit by pressing the ZERO/OFF key. Pressing the TARE key or the ON/PRINT key will change the position of the flashing digit.
9. After entering the exact value, press the NET/GROSS key to save the value. The screen displays "yE_xx" where 'xx' is the current month of the year, e.g. "11". One digit will be flashing.
10. Use the four directional keys to adjust the displayed value to the actual year value. Increase the flashing digit by pressing the UNITS key. Decrease the flashing digit by pressing the ZERO/OFF key. Pressing the TARE key or the ON/PRINT key will change the position of the flashing digit.
11. After entering the exact value, press the NET/GROSS key to save the value and revert up to the parameter level, e.g. "A 20".
12. To save all parameter settings, it is imperative to exit all menus in the following manner: At the parameter level, press the UNITS (up) key twice (two times) to exit the User Menu. The indicator displays 'SAvE' and then automatically powers off.

SYSTEM CALIBRATION

Calibration Overview

Digital system calibration is accomplished in two steps: zero calibration (F16) and span calibration (F17). You may restore factory calibration values via the B6 menu.

In the unlikely event that any calibration value is lost, the setup menu makes provisions for re-entering these values via F19 and F20; thus, eliminating the need for re-calibration with test weights.

For dual wireless A/D modules systems (e.g. TI-500 RFTM-2BE), a digital corner calibration feature is also available. It does not require a specific test weight value, but the maximum weight that should be used is approximately 25% of the rated capacity of the platform.

NOTE: Please perform corner calibration prior to executing zero/span calibration.

Digital Corner Calibration (dual wireless units only)

1. Switch off the RF digital indicator by pressing and holding the ZERO/OFF key for about 5 seconds.
2. Press and hold down the ON/PRINT key (about 20 seconds) until the screen shows "-F-".
3. Press the ON/PRINT key until the screen displays "-B-".
4. Scroll down once using the ZERO/OFF key to enter the "Bluetooth" menu. Scale shows "B 1".
5. While in the Bluetooth Setup mode, scroll to "**B 10**", and then scroll down once using the ZERO/OFF key to enter corner calibration menu. The indicator will display a value. This value is the internal A/D count and can prove useful when trying to troubleshoot setup problems.
6. Remove all items from the weighing platform.
7. Press the NET/GROSS key to save the zero-point value. The display will show "**Corn-1**".
8. Place the test weight on the load cell/corner #1 of the weighing platform.
9. Wait 2-3 seconds to allow the internal reading to stabilize.
10. Press the NET/GROSS key to save the load cell/corner #1 calibration. The display will show "**Corn-2**".
11. Repeat steps 8-10 for the remaining load cells/corners. At the end of corner #4 calibration, the display will show "**Set--**".
12. Press the NET/GROSS key to finish the corner calibration and revert up to B10.
13. To save all parameter settings, it is imperative to exit all menus in the following manner: At the parameter level, press the UNITS (up) key twice (two times) to exit the Bluetooth Menu. The indicator displays 'SAVE' and then automatically powers off.

Digital Zero/Span Calibration (F16 and F17)

1. If already in the "F" menu, press the UNITS (up) key twice (two times) to exit the Setup Menu and save all parameters. Otherwise, switch off the RF digital indicator by pressing and holding the ZERO/OFF key for about 5 seconds.
2. Enter the Setup mode by pressing and holding the ON/PRINT key for about 20 seconds or until the screen shows "F".
3. Scroll down once using the ZERO/OFF key to enter the "Setup" menu. Scale shows "F 1".
4. While in the Setup mode, scroll to "**F 16**", and then scroll down once using the ZERO/OFF key to enter zero calibration menu. The display will momentarily show "**C 0**" followed by a value. This value is the internal A/D count and can prove useful when trying to troubleshoot setup problems.
5. Remove all items from the weighing platform and press the ZERO/OFF key to zero out the displayed value.
6. Press the NET/GROSS key to save the zero-point value. The display will show "**EndC0**" momentarily, and then revert up to F16.
7. Press the ON/PRINT key to progress to the F17 menu.
8. While at the "**F 17**" screen, scroll down once using the ZERO/OFF key to enter span calibration menu. The display will momentarily show "**C 1**" for the span calibration point, followed by a value with one flashing digit.
9. Place the test weight on the weighing platform.
10. Use the four directional keys to adjust the displayed value to the actual test weight value. Increase the flashing digit by pressing the UNITS key. Decrease the flashing digit by pressing the ZERO/OFF key. Pressing the TARE key or the ON/PRINT key will change the position of the flashing digit.
11. After entering the exact value, press the NET/GROSS key to save the value. If the calibration was successful, the display will show "**EndC1**" momentarily, followed by "**C 2**" for the second calibration point.
12. If you require multiple span calibration points, repeat steps 10 and 11 for C2 and C3. Otherwise, simply press NET/GROSS key when prompted for C2.
13. At the end of C3, the indicator displays the current gravity settings, e.g. "9.800". If the local gravity factor is known, then use the up/down and left/right keys to adjust the displayed value. Otherwise, just press the NET/GROSS key. The display will show "-donE".
14. Press the NET/GROSS key to revert up to "F17".
15. If the calibration was *not* successful, one of the error messages below will appear. Take the indicated action to correct the problem, and then perform a new calibration.
 - "**Err0**" - The calibration test weight or the keyed-in weight is larger than the full capacity of the scale. Change the calibration test weight or check the input data.
 - "**Err1**" - The calibration test weight or the keyed-in weight is smaller than 1% of the full capacity of the scale. Change the calibration test weight or check the input data.
 - "**Err2**" – There is not enough signal from the load cells to establish a proper calibration. Most common causes include incorrect load cell wiring, a mechanical obstruction or a faulty (damaged) load cell.

To save calibration data, it is imperative to exit all menus in the following manner: At the parameter level, press the UNITS (up) key twice (two times) to exit the Setup Menu. The indicator displays 'SAvE' and then automatically powers off.

Key-In Zero Calibration Value (F19)

Note: This procedure is intended for emergency use only in the case of non-volatile memory loss. A valid zero calibration value, obtained from a successful F16 calibration procedure, must be used.

1. While in the Setup mode, scroll to "**F 19**", and then scroll down once using the ZERO key. The display will momentarily show "**CAL 0**", then "**E CAL0**" followed by a value of zero
2. Use the four directional keys to enter in the actual zero calibration value.
3. After entering the exact value, press the NET/GROSS key to save the value. The display will revert up to F19.

To save calibration data, it is imperative to exit all menus in the following manner: At the parameter level, press the UNITS (up) key twice (two times) to exit the Setup Menu. The indicator displays 'SAvE' and then automatically powers off.

Key-In Span Calibration Value (F20)

Note: This procedure is intended for emergency use only in the case of non-volatile memory loss. Valid span calibration values, obtained from a successful F17 calibration procedure, must be used.

1. While in the Setup mode, scroll to "**F 20**", and then scroll down once using the ZERO key. The indicator will prompt you to enter the information in the Table below.
2. If the value shown is correct, press the NET/GROSS key to move to the next parameter. Otherwise, use the four directional keys to enter in the actual calibration value
3. After setting the exact value, press the NET/GROSS key to save the value.
4. At the completion of the sequence, the indicator will then revert up to F20.

CODE	NAME
ET T 1	First Test Weight Value
ET C 1	First Span Calibration Value
ET T 2	Second Test Weight Value
ET C 2	Second Span Calibration Value
ET T 3	Third Test Weight Value
ET C 3	Third Span Calibration Value

Calibration Value Entry Table

To save calibration data, it is imperative to exit all menus in the following manner: At the parameter level, press the UNITS (up) key twice (two times) to exit the Setup Menu. The indicator displays 'SAvE' and then automatically powers off.

Restore Factory Calibration (B6) – wireless systems only

Caution: This action cannot be undone.

1. Switch off the RF digital indicator by pressing and holding the ZERO/OFF key for about 5 seconds.
2. Enter the Setup mode by pressing and holding the ON/PRINT key for about 20 seconds or until the screen shows "F".
3. Use the ON/PRINT key to change the display to "B".
4. Scroll down once using the ZERO/OFF key to enter the "Bluetooth" menu. Scale shows "B 1".
5. While in the Bluetooth mode, scroll to "**B 6**".
6. Press the ZERO/OFF key once; the display says "F-CAL".
7. To view all the factory corner calibration values, press the ZERO/OFF key once; the indicator automatically displays the calibration values for each corner (1-4) in sequence and then returns to the "F-CAL" level.
8. To view all the factory span calibration values, press the UNITS key once; the indicator automatically displays the following in sequence and then returns to the "F-CAL" level.
Span Point #1 Weight Value
Span Point #1 A/D Count
Span Point #2 Weight Value
Span Point #2 A/D Count
Span Point #3 Weight Value
Span Point #3 A/D Count
9. To exit without restoring the factory calibration values, press the PRINT key; the indicator reverts up to B6.
10. To restore the factory calibration values, press and hold the NET/GROSS key for 3 seconds; the indicator briefly displays "dOnE" and then reverts up to B6.
11. To save all parameters, it is imperative to exit all menus in the following manner: At the parameter level, press the UNITS (up) key twice (two times) to exit the Bluetooth Menu. The indicator displays 'SAVE' and then automatically powers off.

SERIAL PORT INFO

SERIAL PORT MODES

DEMAND DUPLEX MODE

The Demand Duplex Mode provides a two-way serial transmission mode. In this mode, the output information is transmitted on demand; either by pressing the PRINT key on the indicator's front panel or upon receiving a recognized command from a host device (i.e. computer).

NOTE: Ensure that your cabling contains the proper handshaking.

CONTINUOUS DUPLEX MODE

The Continuous Duplex Mode provides a two-way serial transmission mode. In this mode, the output information is transmitted continuously making it a popular choice for remote displays and other remote devices requiring a constant data stream. The transmission automatically occurs at the end of each display update. The indicator will react upon receiving a recognized command from a host device.

RECOGNIZED HOST COMMANDS (applies to both demand and continuous duplex modes)

- “**P**” - This command is sent to the indicator to print the indicated display. The indicator will not respond if the scale is in motion, positive overload or negative overload.
- “**Z**” - This command is sent to the indicator to zero the scale. The indicator will not respond if the scale is in motion, positive overload or negative overload. The indicator will also not respond if it is not in gross mode or within the zero-range specified in F4 of the Setup Menu.
- “**T**” - This command is sent to the indicator to tare the scale. The indicator will not respond if the scale is in motion, positive overload or negative overload. The indicator will also not respond if it is displaying a negative gross value.
- “**G**” - This command is sent to the indicator to switch to gross mode. The indicator will not respond if the scale is in motion, positive overload or negative overload.
- “**N**” - This command is sent to the indicator to revert to net. The indicator will not respond if the scale is in motion, positive overload or negative overload. The indicator will also not respond if a tare has yet to be established.
- “**C**” - This command is sent to the indicator to toggle among the configured units of measure.

AUTO PRINT MODE

The Auto Print Mode provides a one-time serial transmission once a non-zero, stable condition is achieved.

TEST AND MEASUREMENT MODE

The Test and Measurement Mode is identical to the Demand Duplex Mode with one exception: the indicator will respond to a PRINT command even when the scale is in motion, positive overload or negative overload.

OUTPUT STRINGS

TEXT PRINT TICKET

The Text Print Ticket is designed specifically for a serial printer.

ID. NO.	123456
GROSS	25.00 lb
TARE	1.48 lb
NET	23.52 lb
DATE	03/01/2011

NOTES:

1. The TARE and NET fields are not printed unless a tare has been established in the system.
2. The ID number field is not printed if it is disabled in A7 of the User Menu.
3. The date is not printed if it is disabled in A18 of the User Menu.

STRING FORMAT 1 (Condec Demand String)

String Format 1 is designed for two-way communication.

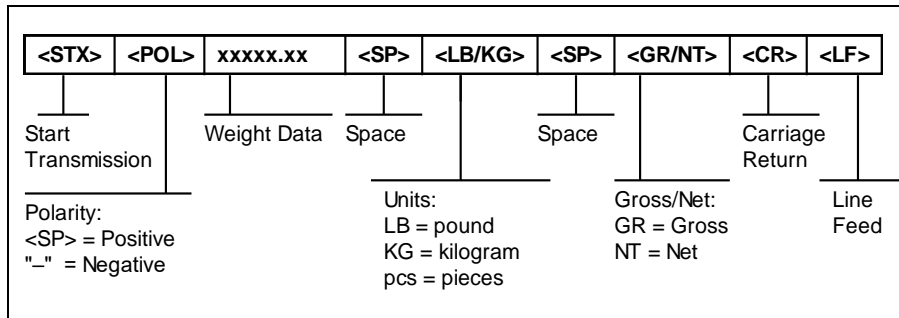

STRING FORMAT 2 (Condec Continuous String)

String Format 1 is designed for one-way communication.

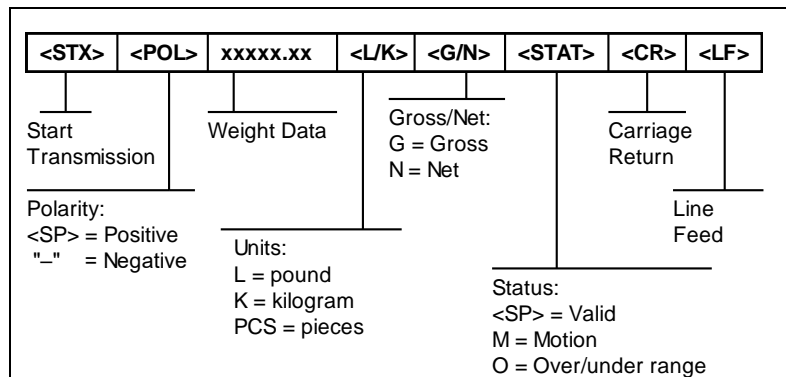

Contents subject to change without notice.

Transcell Technology, Inc.
975 Deerfield Parkway
Buffalo Grove, IL 60089
Tel (847) 419-9180
Fax (847) 419-1515
Web: www.transcell.com